

Rovanco HDPE Jacketed System

For Temperatures to 210°F Above* and Below Ground

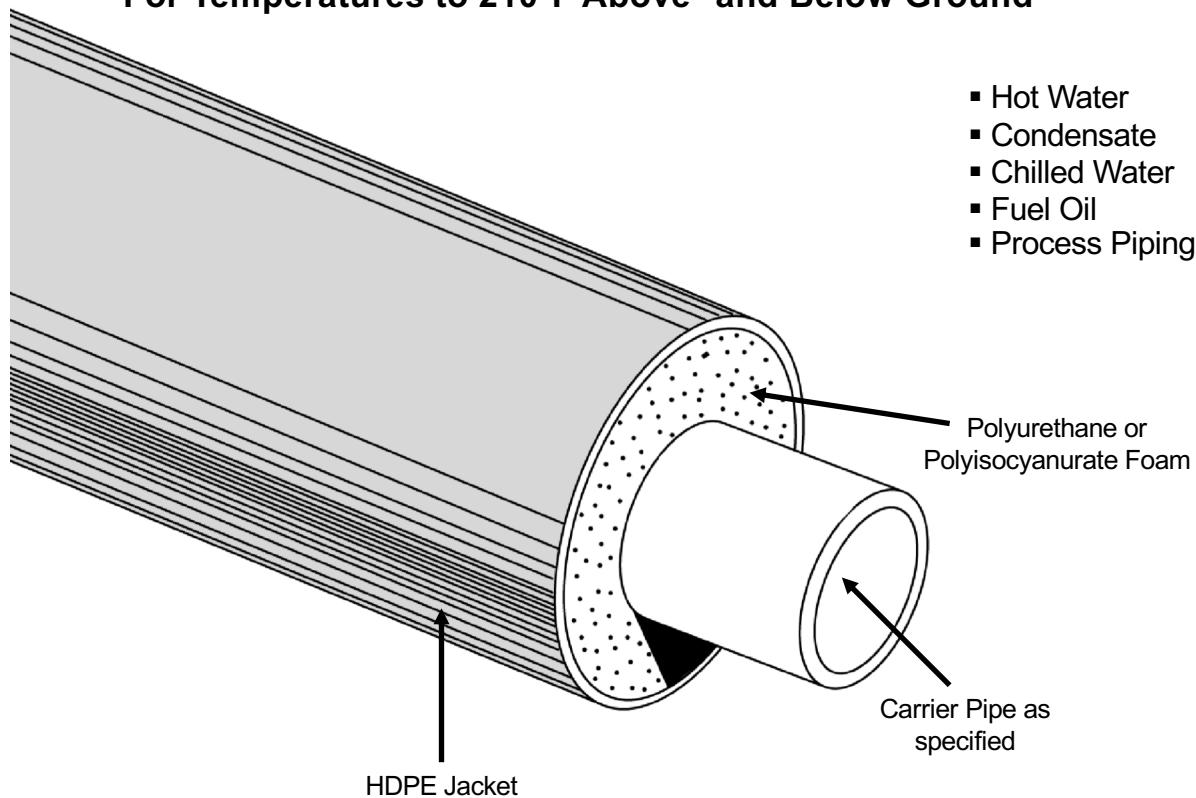

Rovanco's High Density Polyethylene (HDPE) Jacketed System is designed for piping systems above and below ground suitable for inside and outside applications. Carrier pipe insulation is either a polyurethane or polyisocyanurate high quality foam, combined with a durable watertight jacket supplied in 20' or 40' random lengths, means an economical, high-quality system.

Rovanco's System is provided with a jacketing of HDPE, which can be supported from the outside with maximum supports spans. Fittings can be either field insulated or factory fabricated as specified.

The HDPE System comes complete with the carrier pipe of your choice, insulation of your choice, joint insulation materials and jacketing to make the installation completely watertight for applications of process fluids, hot water, pumped condensate, chilled water, etc.

To find out more about Rovanco's HDPE System, you can visit our factory, phone us (815) 741-6700, fax us (815) 741-4229, visit our website at www.rovanco.com or e-mail us at marketing@rovanco.com.

*For higher temperatures, consult factory.

This is a generic product datasheet and is not intended for submittal use.

SPECIFICATION FOR HDPE Jacketed SYSTEM

Steel Piping Systems for Low Pressure Steam, Condensate, Chilled or Hot Water, Fuel Oil, and Process Piping Applications

Carrier Pipe Types:

HDPE

The pipe shall be made of polyethylene resin compound with a minimum cell classification by PE445474C for PE4710 materials per ASTM P3350 and D2837. Shall contain 2% dispersed carbon black.

Piping and fittings are available in 10 different pressure classes as designated by dimensional ratios (DR) from 32.5 at 50 psi through 6.3 at 300 psi for water service at 73°.

Assembly is by thermal butt fusion for a fast, economical; and long-term performance installation.

PVC

Sch 40/80 solvent weld. Other classes and schedule of PVC pipe are available.

Type (K) or (L)

Hard Drawn Copper Tubing conforming to ASTM M-88.

Steel

A-53 Grade B ERW in Schedule (40) or (80). Pipe 10" and above will be standard weight .375 wall or extra heavy .500 wall.

Fiberglass

Series 3000A Bondstrand* filament wound fiberglass reinforced epoxy, bell and spigot, designed to withstand 210°F. Pipe to be in conformance with MIL-SPEC P29206A.

Other carrier pipe types are available upon request. Factory fabricated and pre-engineered to actual field dimensions.

Polyurethane Insulation:

Insulation shall be a polyurethane foam injected with one shot into the annular space between carrier pipe and jacket. Insulation shall be rigid, minimum 90% closed cell polyurethane with a minimum 2.0 lbs per foot³ density, compressive strength of 30 psi @ 75°F and a thermal conductivity K factor no higher than 0.180 @ 75°F per ASTM C-518. Maximum operating temperature of urethane foam shall not exceed 250°F.

Polyisocyanurate Insulation:

Insulation shall be a polyisocyanurate foam injected with one shot into the annular space between carrier pipe and jacket. Insulation shall be rigid, >90% closed cell polyisocyanurate with a minimum 2.0 lbs per foot³ density, compressive strength of 30 psi @ 75°F, a thermal conductivity K factor no higher than 0.121 @ 75°F per ASTM C-518 and an E84 25/50 passive fire resistance rating. Maximum continuous operating temperature of polyisocyanurate foam shall not exceed 300°F.

Also available in a 400°F polyisocyanurate foam.

Jacketing Material:

The outer casing shall be high density polyethylene (HDPE) conforming to ASTM D3350. Type III, Category 5, Class C and Grade P23/P34. With a minimum of 2% by weight of carbon black. Minimum thickness is 150 mils. No FRP overwrap or sprayed jacketing will be allowed. Minimum jacket thickness shall be in accordance with Table 1:

Table 1:

Nominal Pipe Size In Inches	Minimum Insulation Thickness In Included	Jacket Size In Inches	Jacket Thickness In Mils
1-1/2	2.15	6.60	200
2	1.91	6.6	200
2-1/2	1.66	6.60	200
3	1.35	6.60	200
4	1.57	8.00	175
5	2.04	10.00	175
6	1.51	10.00	175
8	1.72	12.43	175
10	1.48	14.06	175
12	1.38	15.87	175
14	1.74	17.83	175
16	1.7	19.80	200
18	1.89	22.17	200
20	1.86	24.17	225

* Larger Pipe Sizes are available upon request.

Joining Method:

Straight lengths of pipe will be joined by HDPE electro-fusion fittings.

Fitting:

All fittings will conform to pipe type and will be insulated and jacketed with materials supplied by the system supplier as per manufacturers' standard procedures.

End Seals:

Each length of pre-insulated pipe will be fitted with a watertight mastic end seal at jacket and pipe surfaces. All field cuts will be sealed with a field applied end seal.

Insulation of Straight Joints:

After welding and testing, all joints shall be insulated and sealed as per manufacturers' standard procedures.

Backfill: (if below ground)

Should be tamped compactly in place so as to assure a stable surface. No rock should be used in the first foot of backfill. 24 inches, top to pipe to grade, of compacted fill shall meet H-20 Highway Loading.

Manufacturer's Assistance:

Rovanco will provide a field service man on-site to properly train the installing personnel in all phases of installation, (if required).

Approved Vendors:

HDPE Piping Systems by Rovanco, Joliet, Illinois or approved, ISO certified, equal. Any alternate supplier must submit their technical data to the engineer ten days prior to bid date to be approved in writing as an equal.

cc #06012023

Copyright 2023 – Rovanco's products are covered by various U.S. patents. Rovanco & Insul-8 are federally registered trademarks.

Contact Rovanco® for the name of your local Representative

20535 S.E. Frontage Road • Joliet, Illinois 60431 • (815) 741-6700

Website: www.rovanco.com • E-mail: marketing@rovanco.com

This is a generic product datasheet and is not intended for submittal use.